



CITY OF EAGLE LAKE

WHERE OPPORTUNITY SOARS

City of Eagle Lake

**MINIMUM
24 HOUR NOTICE ON
ALL INSPECTIONS
CALL TOLL FREE:
1-877-333-5620**

Egress Window Requirements for Building Permit Application

1. Completed Building Permit application form with signature.
2. Submit two (2) copies of plans showing proposed designs and materials; plans shall be drawn to scale and shall include a floor plan indicating the following:
 - a) Existing/Proposed size of opening for window.
 - b) Indication of room use (i.e. bathroom, bedroom, laundry, family room).
 - c) Required installation of smoke detectors (see below).

Required Installation of Smoke Detectors

1. When interior alterations, repairs or additions requiring a permit occur, or when one or more sleeping rooms are added or created, smoke detectors shall be installed throughout the existing dwelling as required for new dwellings; the smoke detectors shall be interconnected and hard wired. (Exception: When alterations/repairs do not result in the removal of interior walls or ceiling finish, unless there is an attic, crawl space or basement available which could provide access).
 - a) One in each sleeping room.
 - b) One outside of each separate sleeping area in the immediate vicinity of the bedrooms.
 - c) A smoke detector shall be installed on each story and in the basement
 - d) In dwellings when a story or basement is split into two or more levels the smoke detector shall be installed on the upper level except when the lower level contains a sleeping area, a detector shall be installed on each level.

General Building Requirements

1. Basements in dwelling units and every sleeping room shall have at least one operable window or door approved for emergency escape or rescue. The emergency door or window shall be operational from the inside to provide a full clear opening without the use of separate tools.
2. Escape or rescue windows shall be a minimum net clear operable area of 5.7 square feet. The minimum net clear operable height shall be 24 inches and the minimum net clear operable width shall be 20 inches. Escape or rescue windows shall have a finished sill height of not more than 44 inches above the floor. (Exception: grade floor opening (not more than 44' above or below grade) shall have a net clear opening of 5 square feet.

3. Window wells for escape or rescue windows shall comply with the following:
 - a) The clear horizontal dimensions shall allow the window to be fully opened and provide a minimum accessible net clear opening of 9 square feet, with a minimum dimension of 36 inches.
 - b) Window wells with a vertical depth more than 44 inches shall be equipped with an approved permanently affixed ladder or stairs that is accessible with the window in the fully open position. The ladder or stairs shall not encroach into the required dimensions of the window well by more than 6 inches.
 - c) Bars, grilles, covers, screens or similar devices are permitted to be placed over emergency escape or rescue window wells, provided they are releasable or removable from the inside without the use of a key, tool or force greater than that which is required for normal operation of escape or rescue opening.

Note: The aforementioned criterion represents general code requirements relative to egress windows. For specific code requirements, please contact the Building Inspection Department or Zoning Department at City Hall.

Required Inspections

1. Framing
2. Final

- *The State of Minnesota requires that all residential building contractors, remodelers and roofers obtain a state license unless they qualify for a specific exemption from the licensing requirements. Any person claiming an exemption must provide a copy of a Certificate of Exemption from the Department of Commerce to the City before a permit can be issued.*
- *To determine whether a particular contractor is required to be licensed or to check on the licensing status of individual contractors, please call the Minnesota Department of Commerce at 651-296-2594 or toll free at 1-800-657-3602.*

If you should have any questions, please call the Building Official.

For inspections call the Building Official at 507-333-5620 or toll free at 1-877-333-5620 between 7:00 a.m. and 4:30 p.m. Monday through Friday.

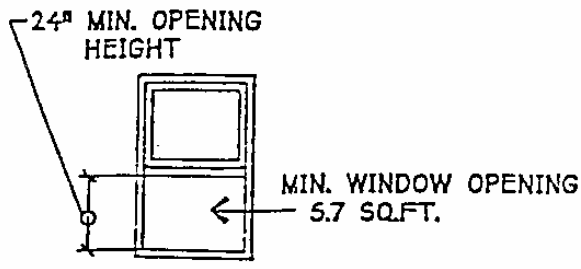

DOUBLE-HUNG

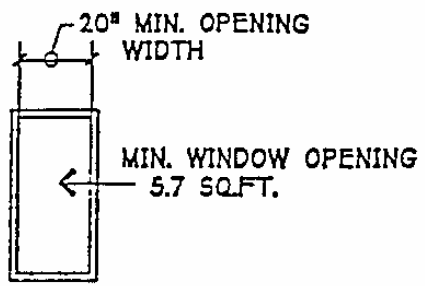

CASEMENT

WINDOW ELEVATIONS

(A)

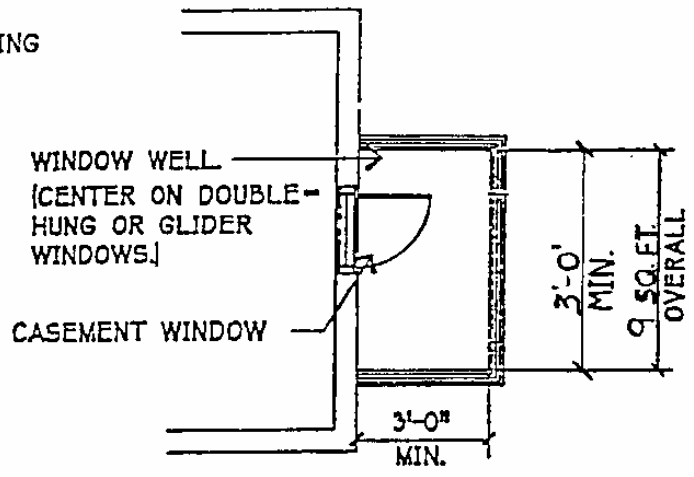

(B) PARTIAL PLAN

"GUARDRAIL-TYPE" RAILING REQUIRED IF NEAR PROPERTY LINE OR SIDEWALK

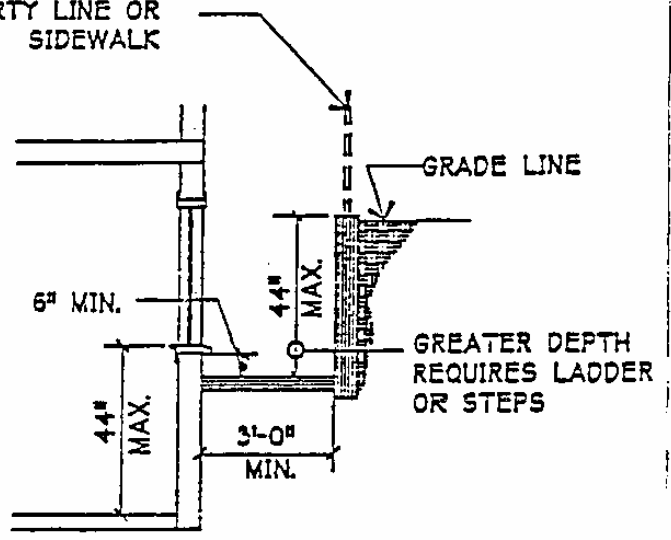

(C) SECTION

EGRESS WINDOWS

TYPICAL BASEMENT EGRESS WINDOW & WINDOW WELL

Scale: 1/2" = 1'-0"

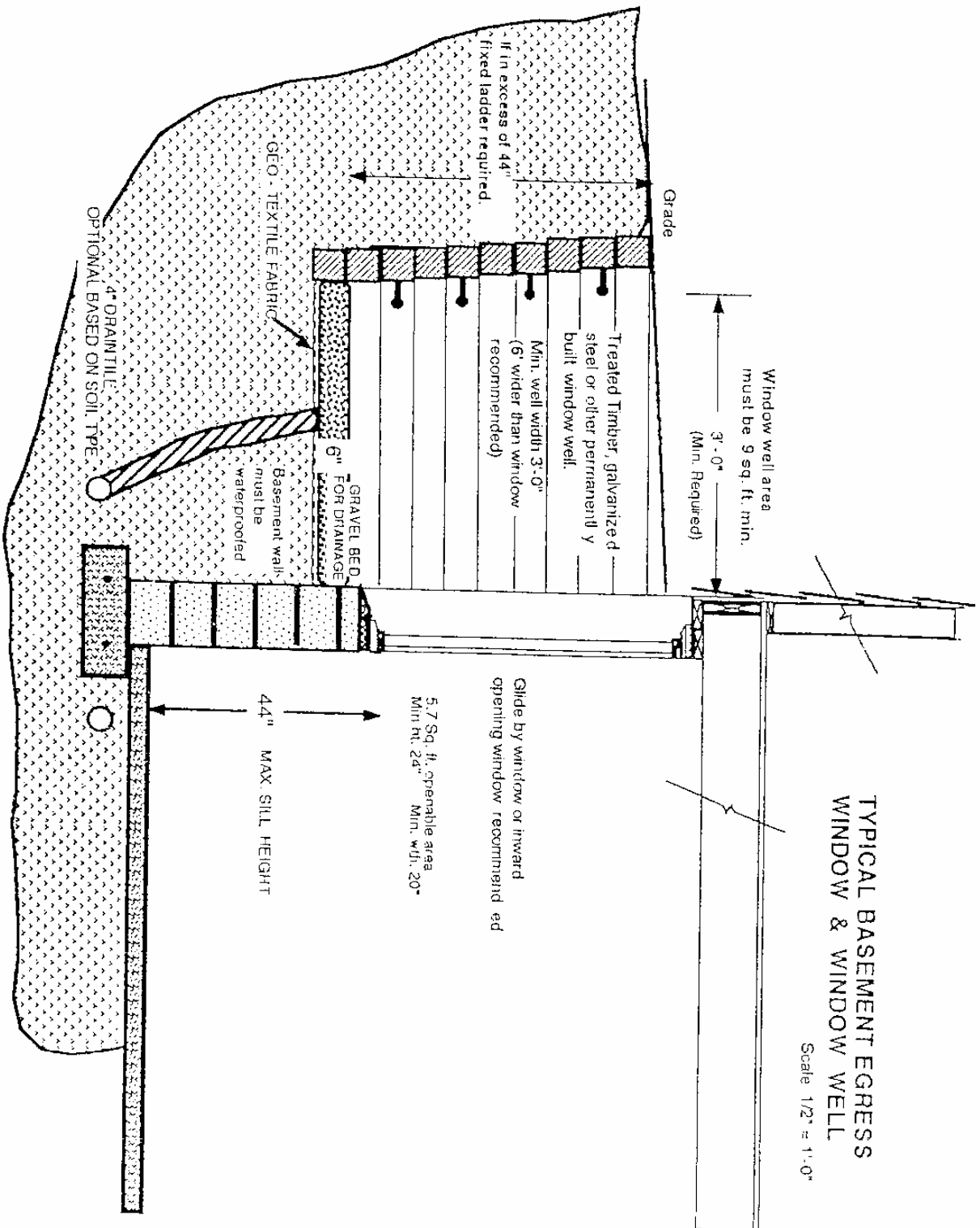

ACCESS AND EXIT FACILITIES AND EMERGENCY ESCAPES

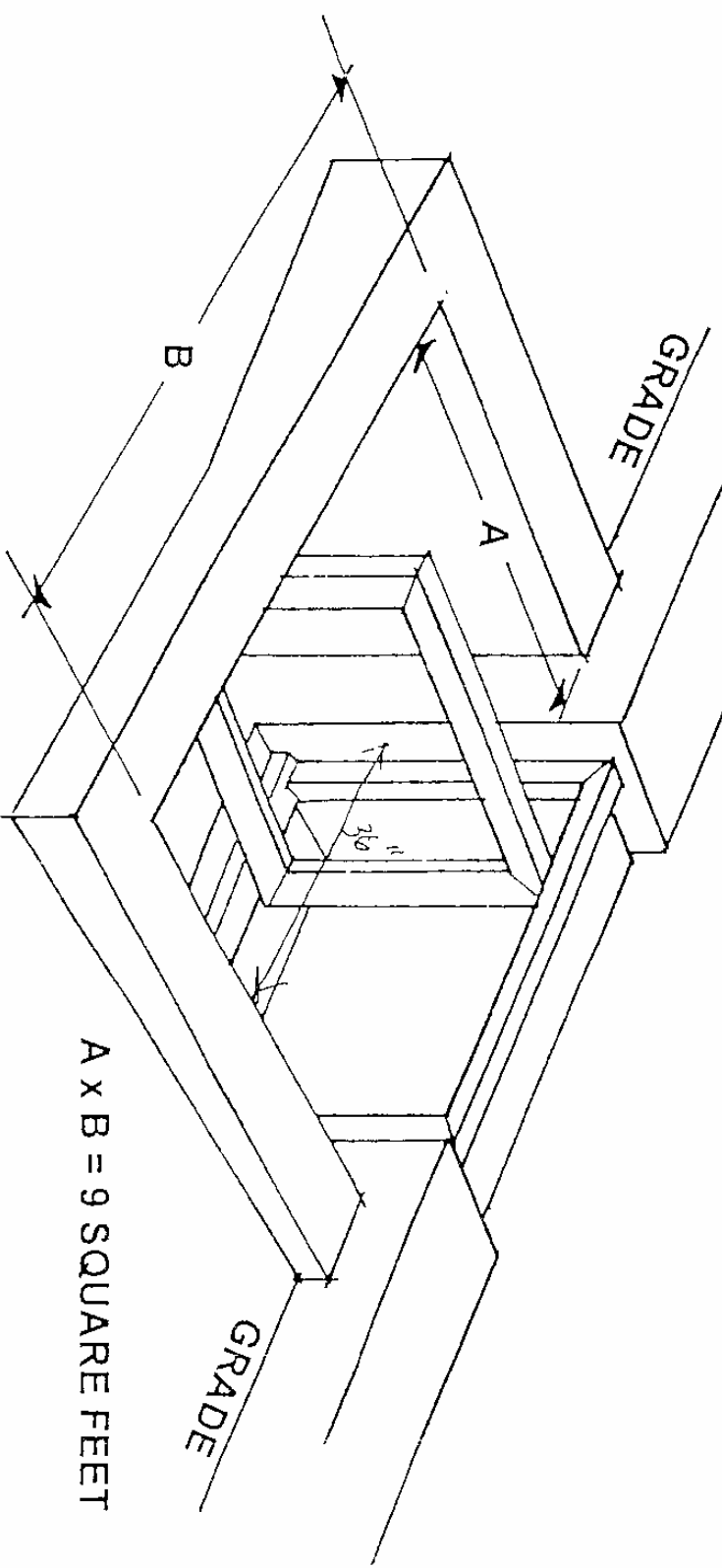

The clear horizontal dimensions shall allow the window to be fully opened and provide a minimum accessible net clear opening of 9 square feet, with a minimum dimension of 36 inches.

ACCESS AND EXIT FACILITIES AND EMERGENCY ESCAPES

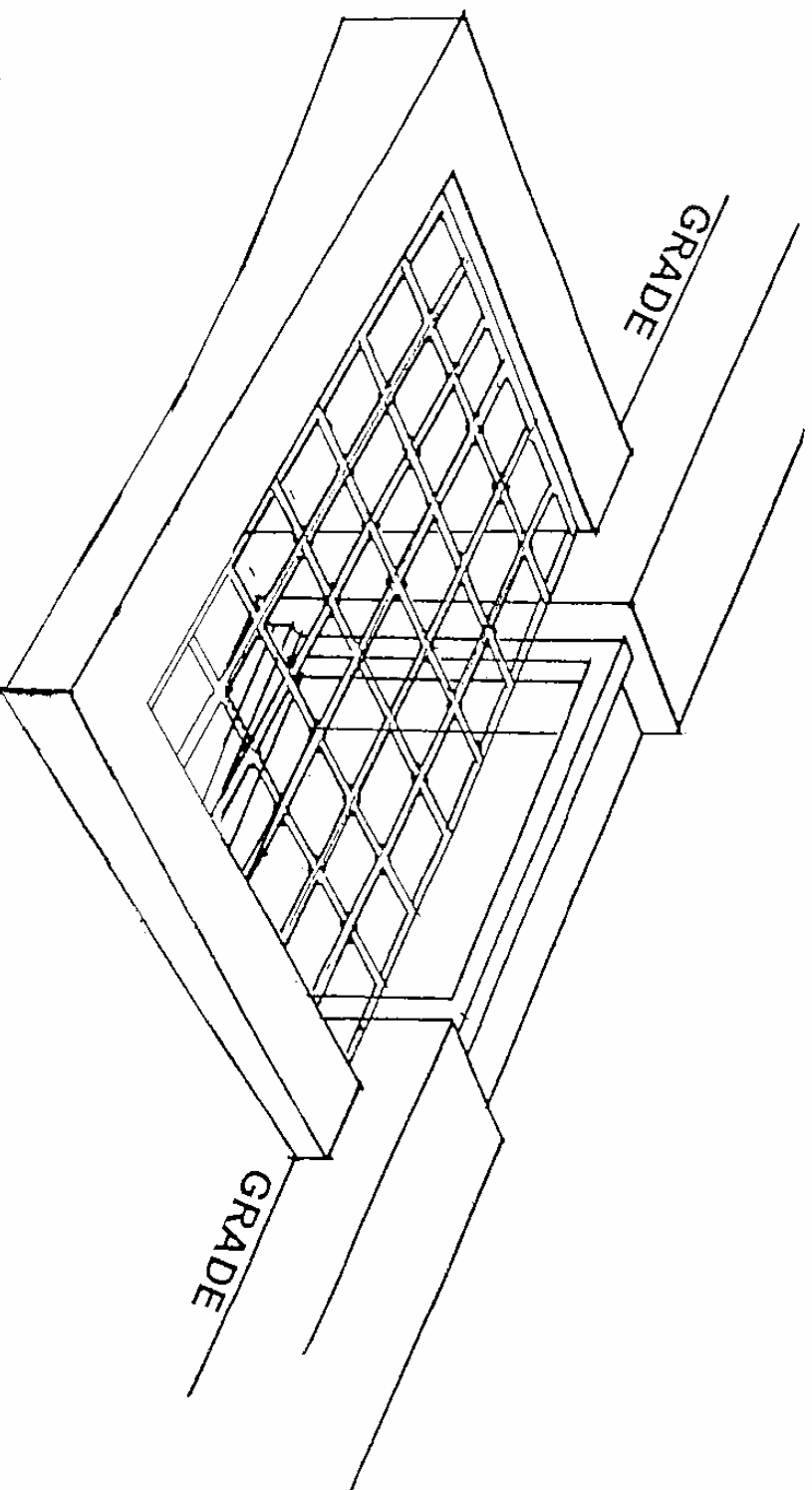

Bars, grilles, covers, screens or similar devices are permitted to be placed over emergency escape or rescue windows, doors or window wells, provided that the devices are releasable or removable from the inside without the use of a key, tool or force greater than that which is required for normal operation of escape or rescue opening.



Building Code Interpretation

Inquiry: 98-48c (formally 96-3)

Subject: Basement Egress Windows

Code: 1994 UBC Section 310.4
(*yr., title, section*)

Submitted By: MN BO Uniformity Committee

Approved By: Thomas R. Joachim
State Building Official

Issue Date: August 3, 1998 (previously July 22, 1996)

Question #1: If I finish my basement into more usable living space, must I install an egress window even though the space does not include a bedroom?

Answer #1: No. The committee interprets that this would only apply to new construction or additions to existing basements.

Committee Comments: The committee will be proposing a code change to clarify that existing basements are exempt from this requirement.

Question #2: Is a guardrail required on the top of egress window wells that are adjacent to walkways not used as required exits?

Answer #2: No. The building code does not address this particular situation. (however, see 509.1 for ramps)

Adopted by committee November 8, 1995 and approved (with deletion) at the 40th Annual Institute of Building Officials on January 12, 1996



Building Code Interpretation

Inquiry: 98-48a (formally 97-35)

Subject: Sleeping Room Window Sash Replacements

Code: 1994 UBC Sections 310.4 and 3402
(yr., title, section)

Submitted By: MN B.O. Uniformity Committee

Approved By: Thomas R. Joachim
State Building Official

Issue Date: August 3, 1998 (previously July 18, 1997)

Question: What minimum net clear opening dimensions and sill mounting height are required after replacing the window sashes with either a pocket unit (sashes and new jambs) or new sash and jamb liners?

Answer: As this work is considered maintenance, the remodeled windows need only comply with any code provisions in effect when they were originally installed.

Division Comments: Although sash replacement normally reduces the openable area in some cases up to an inch on all sides, this work is still considered maintenance and does not generally diminish any life safety. The reliability afforded by new sash and jambs should be considered as offsetting any minor reduction in openable area because of new jamb liners.

Adopted by committee September 25, 1996 and ratified at the 41st Annual Institute of Building Officials on January 17, 1997.



Building Code Interpretation

Inquiry: 98-48b (formally 96-5; revised)

Subject: Sleeping Room Window Replacements

Code: 1994 UBC Sections 310.4, 3402 & 3404
(yr., title, section)

Submitted By: MN B.O. Uniformity Committee

Approved By: Thomas R. Joachim
State Building Official

Issue Date: August 3, 1998 (previously July 22, 1996)

Situation #1: An existing sleeping room's entire escape/rescue window is removed and there is no change in the rough opening. Does the replacement window need to comply with UBC Section 310.4?

Answer #1: No. As this is considered maintenance under UBC Section 3402, the new window unit need only comply with any code provisions in effect when the original window was installed, but be no more hazardous.

Situation #2: A building is moved into or within the jurisdiction. The sleeping rooms do not comply with Sec. 310.4.

Answer #2: UBC Sec. 3404 requires that "buildings or structures moved into or within the jurisdiction shall comply with the provisions of this code for new buildings or structures."

Situation #1:

Adopted by committee November 8, 1995 and approved (with deletion) at the 40th Annual Institute of Building Officials on January 12, 1996.

Situation #2:

Adopted by committee November 20, 1997 and approved at the 42nd Annual Institute of Building Officials on January 16, 1998.